

Quick Installation Guidance

Model:LFP 2400/2500/5000

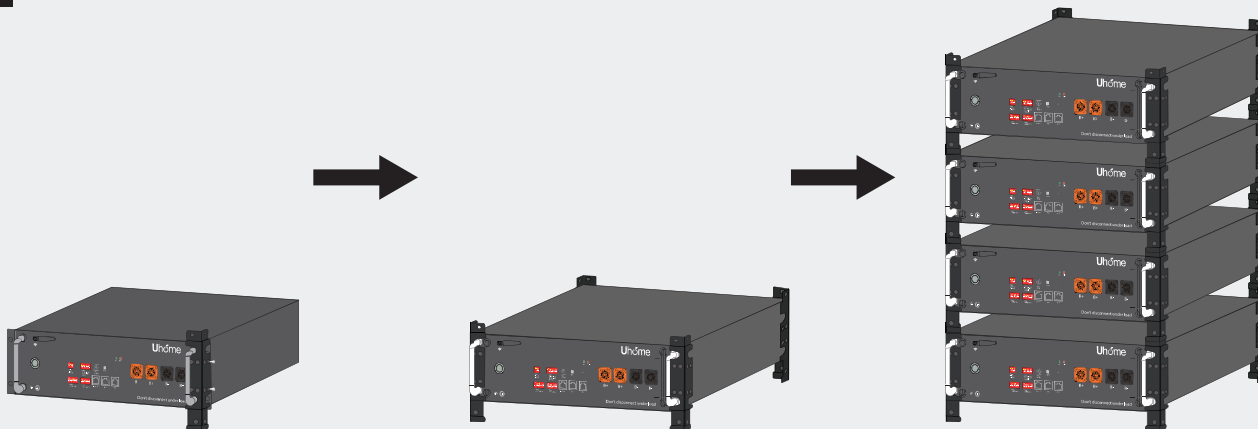

01 Ground Installation



02 Wall Mounting

Position board

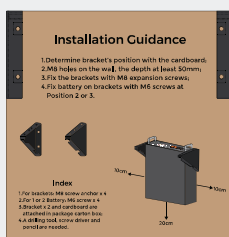

Drill holes of M8 in the wall at least 50 mm depth according to the positioning cardboard

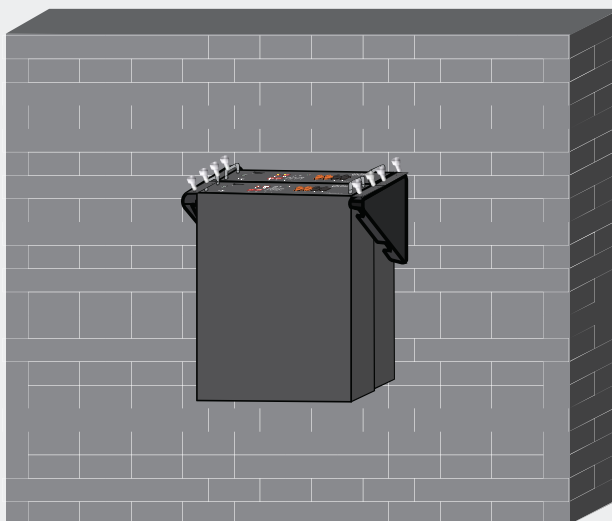

03 Series Connection-Rack Mounted

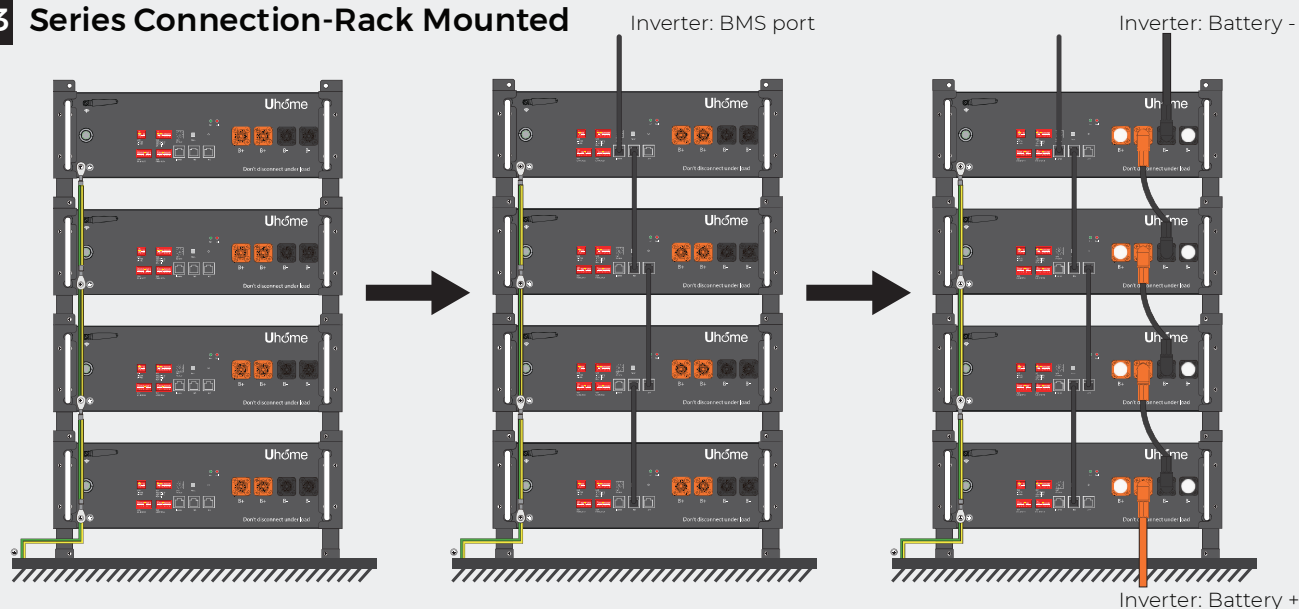

04 Parallel Connection-Rack Mounted

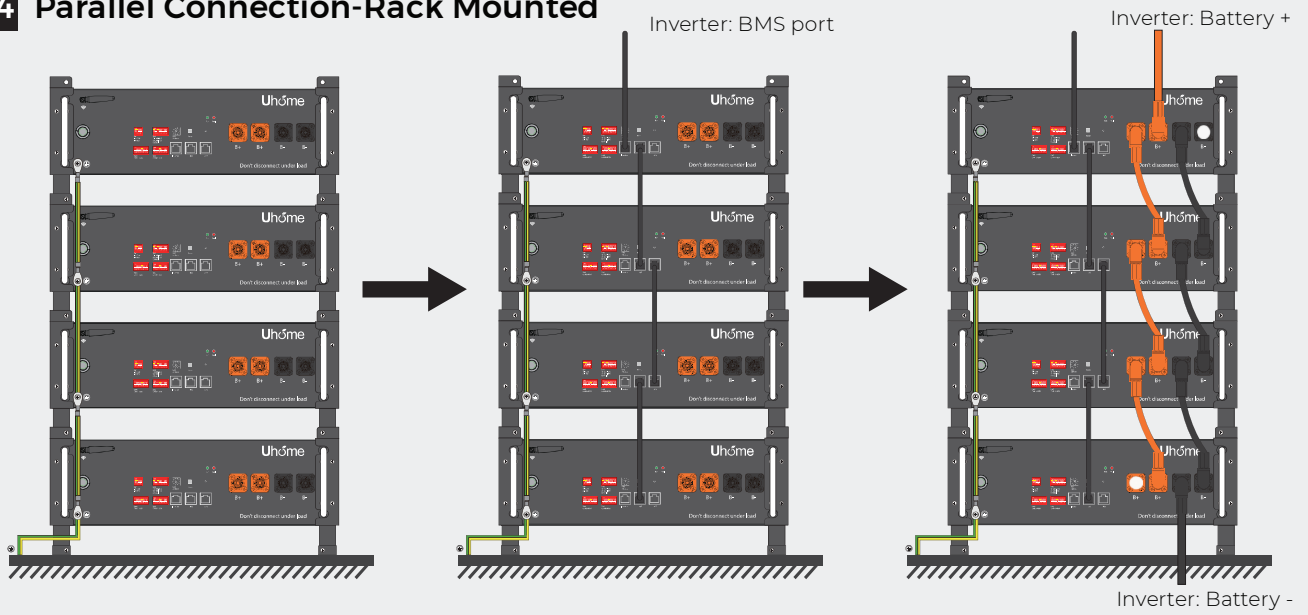

05 Series Connection -Wall Mounting

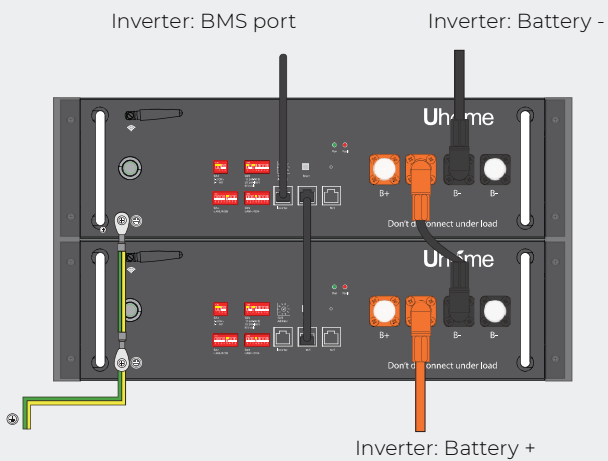

06 Parallel Connection -Wall Mounting

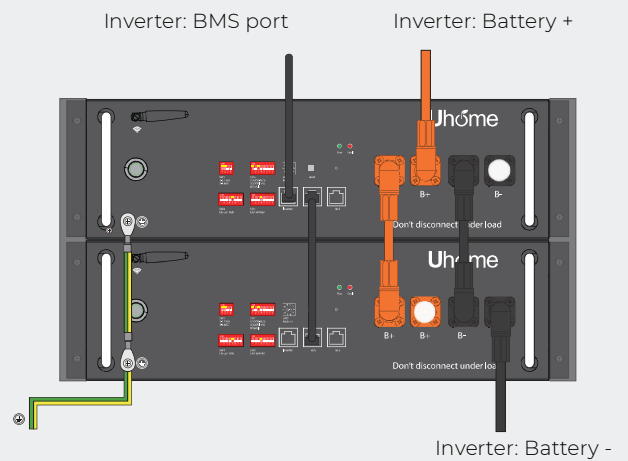

07 Battery Address DIP Switch Setting

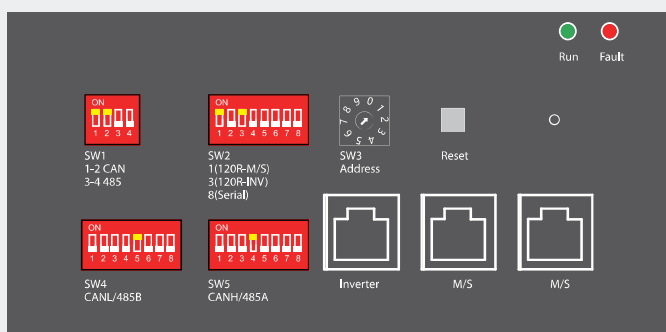

For Parallel connection, SW2 DIP 8 select 'OFF'

For Series connection, SW2 DIP 8 select 'ON'

Series Connection

1 Battery

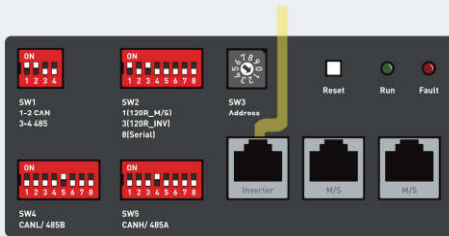

Parallel Connection

1 Battery

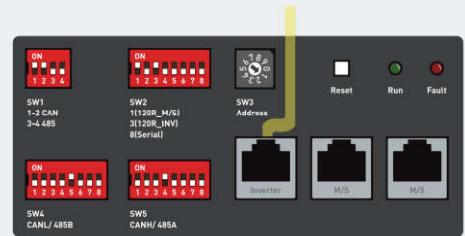

Series Connection

2 Batteries

Master

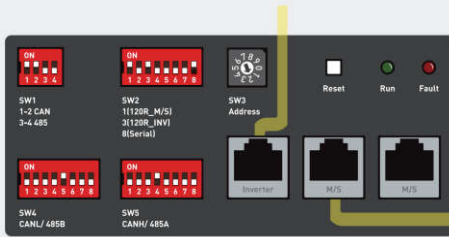

Slave 1

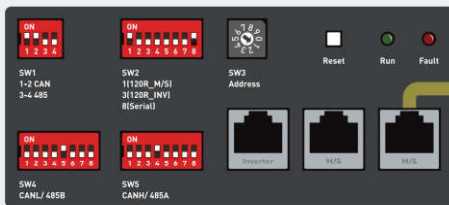

Parallel Connection

2 Batteries

Master

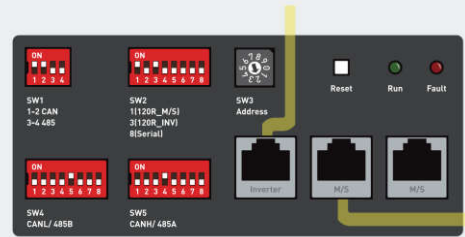

Slave 1

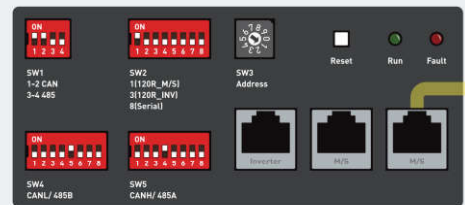

Series Connection

3 Batteries

Master

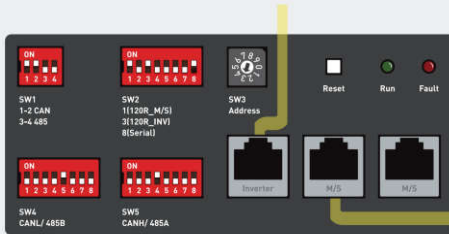

Slave 1

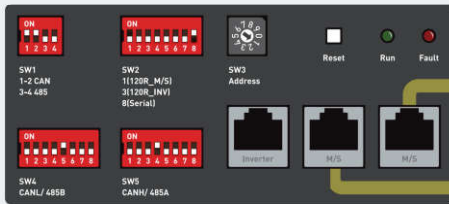

Slave 2

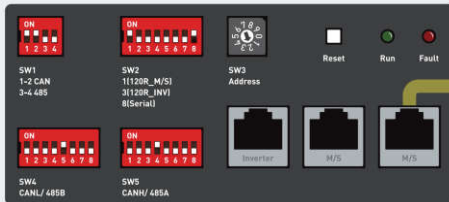

Parallel Connection

3 Batteries

Master

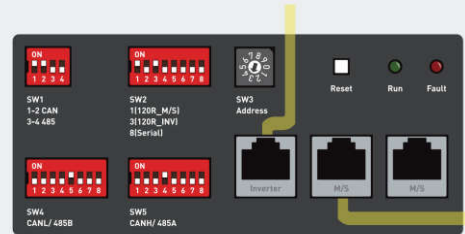

Slave 1

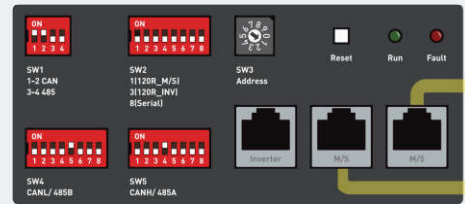

Slave 2

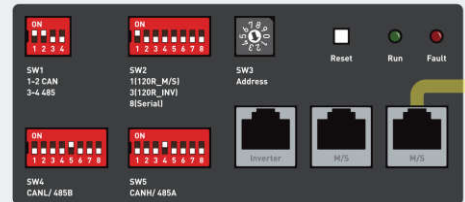

Series Connection

4 Batteries

Master

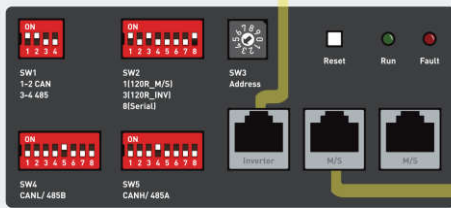

Slave 1

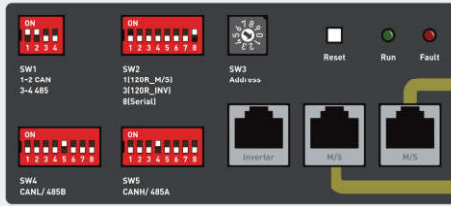

Slave 2

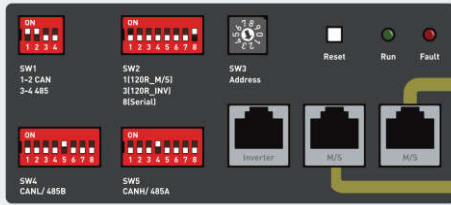

Slave 3

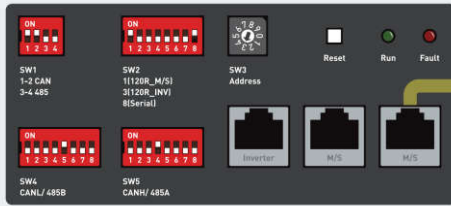

Parallel Connection

4 Batteries

Master

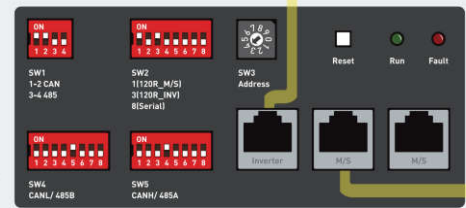

Slave 1

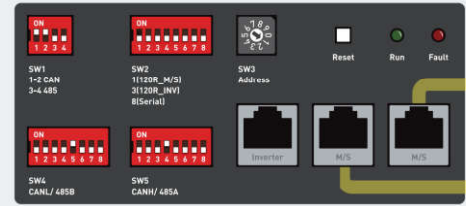

Slave 2

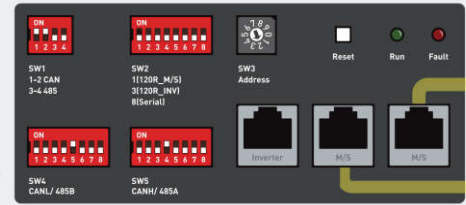

Slave 3

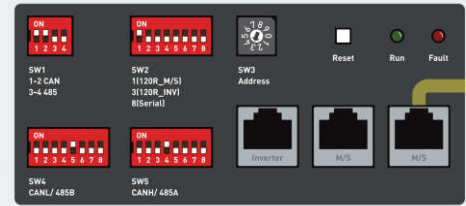

Series Connection

6 Batteries

Master

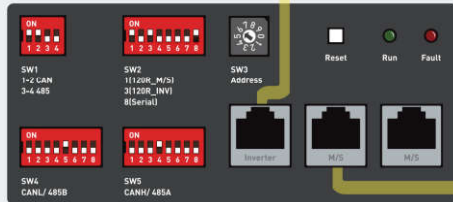

Slave 1

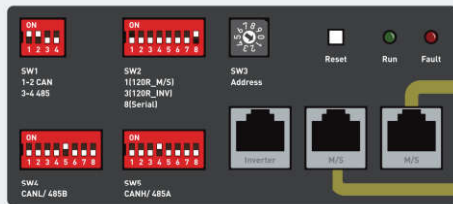

Slave 2

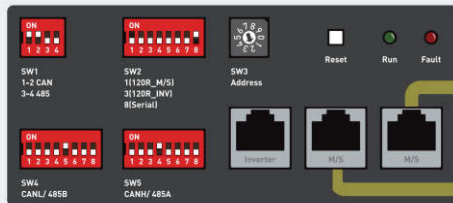

Slave 3

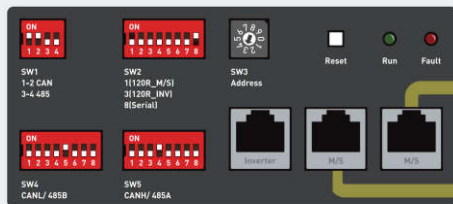

Slave 4

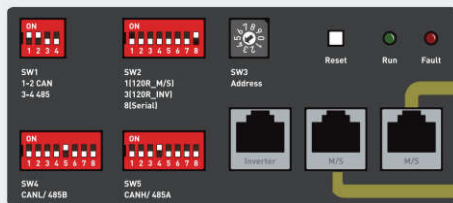

Slave 5

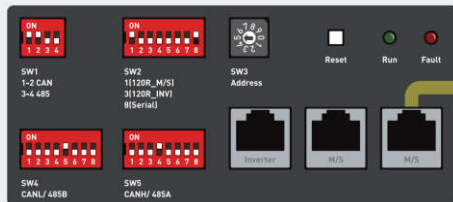

Parallel Connection

6 Batteries

Master

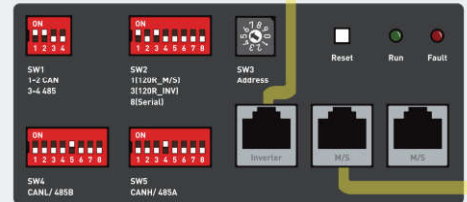

Slave 1

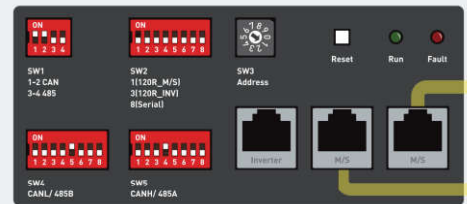

Slave 2

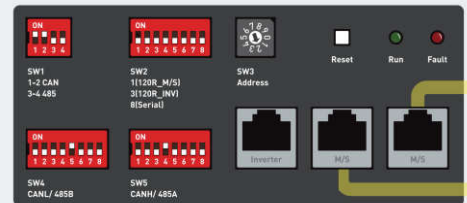

Slave 3

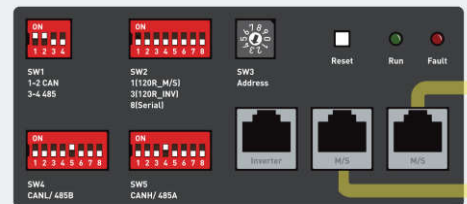

Slave 4

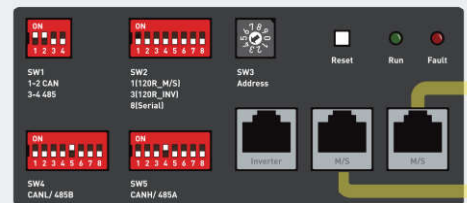

Slave 5

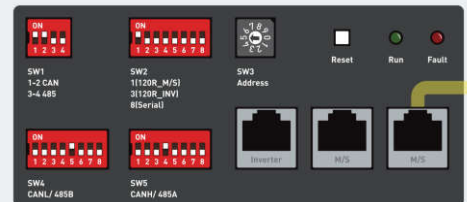

Series Connection

8 Batteries

Master

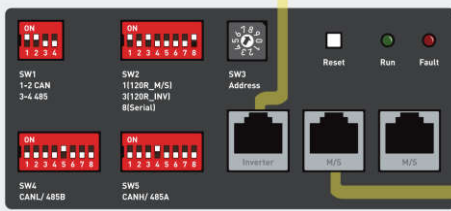

Slave 1

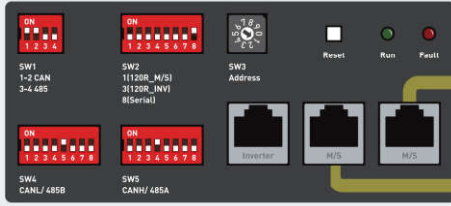

Slave 2

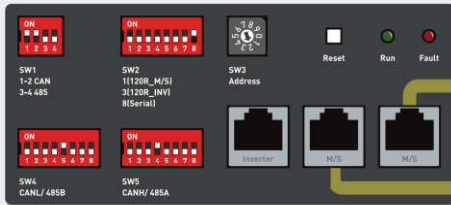

Slave 3

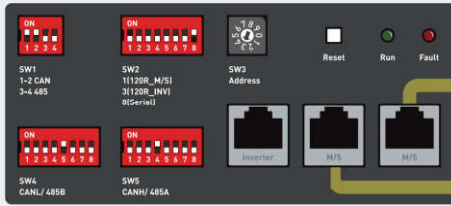

Slave 4

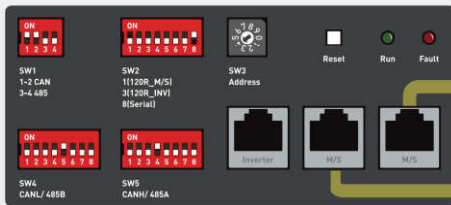

Slave 5

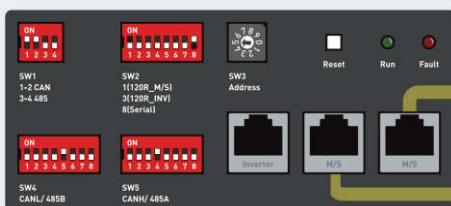

Slave 6

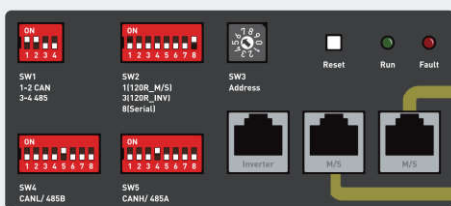

Slave 7

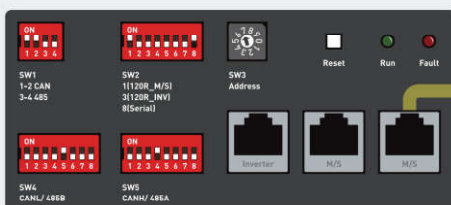

Parallel Connection

8 Batteries

Master

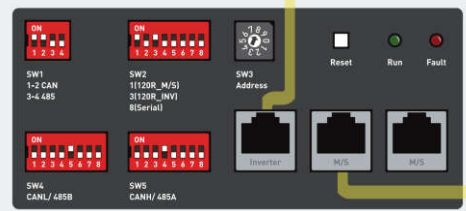

Slave 1

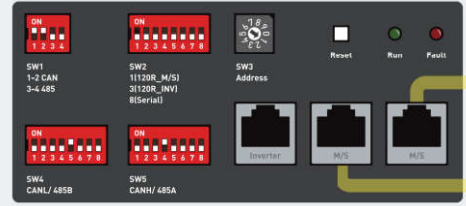

Slave 2

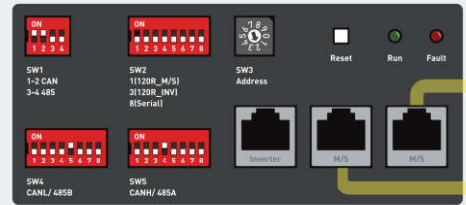

Slave 3

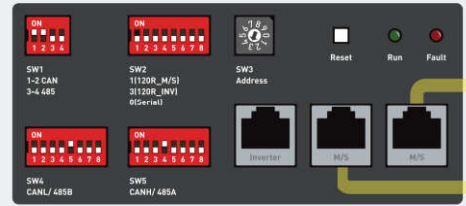

Slave 4

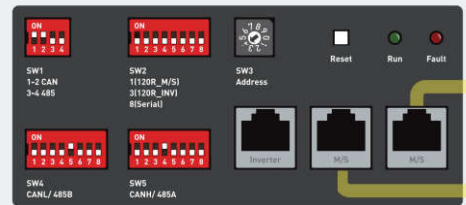

Slave 5

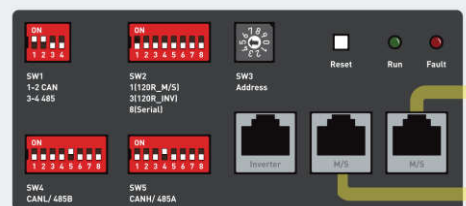

Slave 6

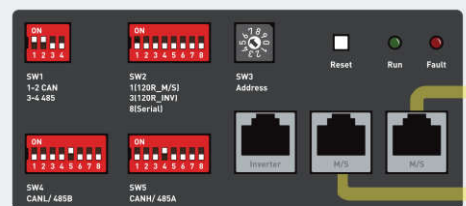

Slave 7

